

ARMG

Anish Rapid Mixer Granulator



Anish Rapid Mixer Granulator is used for tablet formulation by wet Granulation to reduce processing time, homogeneous mixing, and uniformity of Granules size

Salient Features:

- Consists of Mixing Bowl, Impeller, Granulator/chopper, inline Co-mill, Side discharge mechanism
- Mixing Bowl assist mixing of cohesive powders
- Unique impeller design significantly improves pre-mixing efficiency
- Impeller lifting option for ease of cleaning
- High speed granulator (Chopper): assist blending of powder & formation of granules & break lumps into required size granules. Granulator rotates at two speeds-1440/2880.
- Inline co mill with discharge port: to reduce oversized lumps resulting in reduced drying time
- Hydraulic / mechanical lid lifting arrangement
- Hassle free cleaning dismantling and assembling
- cGMP compliant safe cleaning & validation
- Advanced automation with regulatory compliance control
- Contact parts: SS 316/316L

ARMG

Anish Rapid Mixer Granulator

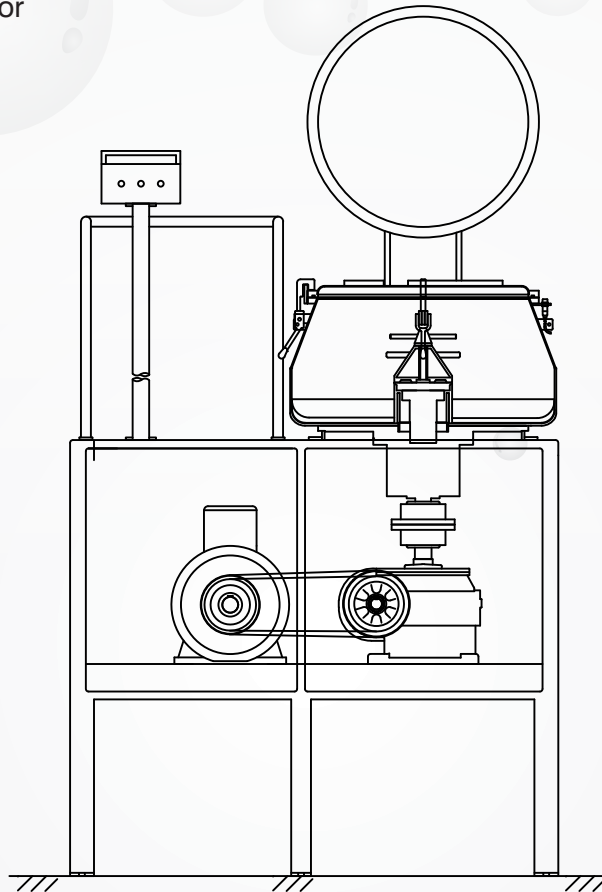

Models:

	R&D Model				Pilot Model			Commercial Model					
	ARMG-5	ARMG-10	ARMG-15	ARMG-25	ARMG-100	ARMG-150	ARMG-250	ARMG-400	ARMG-600	ARMG-800	ARMG-1000	ARMG-1250	ARMG-1500
Capacity (in litre)	5	10	15	25	100	150	250	400	600	800	1000	1250	1500



anish pharma equip pvt. ltd.

Works: G-68, MIDC Ambad, Nasik,
Maharashtra, India 422010
Tel.: +91 253 2381831/2380337
Fax: +91 253 2380903

Office: B-613, Lodha Supremus Tower II,
Wagle Estate, Thane (W),
Maharashtra, India 400604
T.: +91 22 49765310/311

E: marketing@anishpharma.com | M: +91 8380033063 / +91 8380033064
W: www.anishpharma.com